

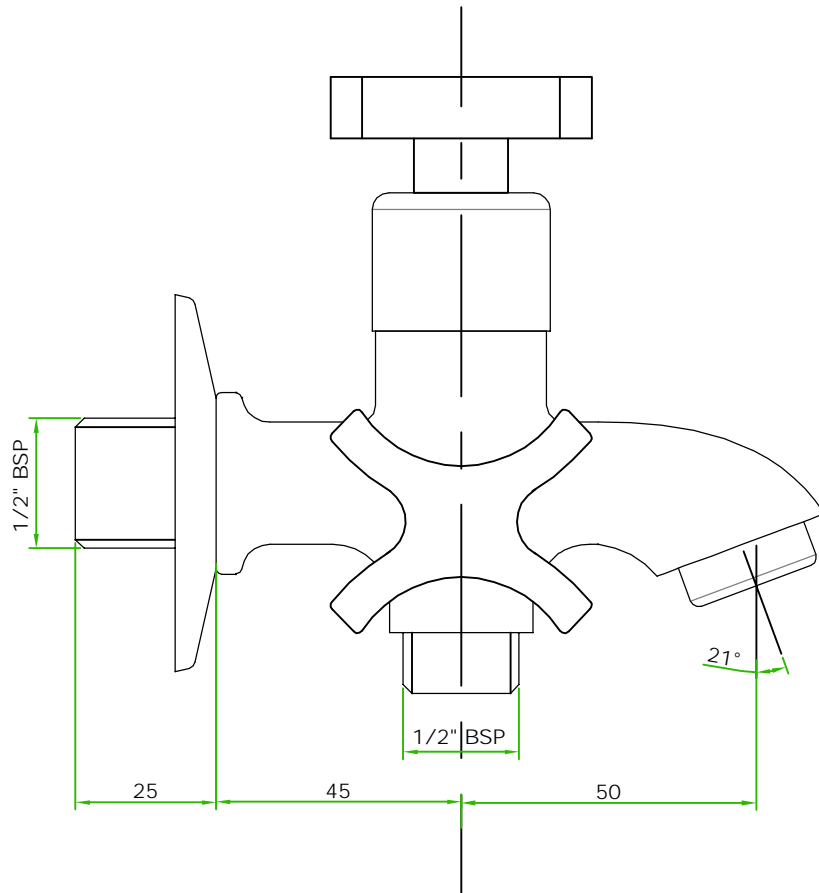

GENERAL TOLERANCE ±0.1mm UNLESS SPECIFIED



REV NO.	DESCRIPTION	DATE	APPROVED BY	SIGN.

SCALE:- NTS	APP. BY:-	DATE :-	NOTE:- ALL DIMENSIONS ARE IN mm	
SHEET SIZE A4	CKD BY:-	RANGE:-		
	DRWN BY:-	PART NAME:-	WEIGHT:-	
	MATERIAL:	7412	DWG NO.	
			TYPE :- MACHINED	

PRAYAG POLYMERS(P) LTD.
A-1129 PHASE -III RIICO INDI ARFA BHIWADI(RA J)