

1

2

3

4

5

6

7

8

GENERAL TOLERANCE ±0.1mm UNLESS SPECIFIED

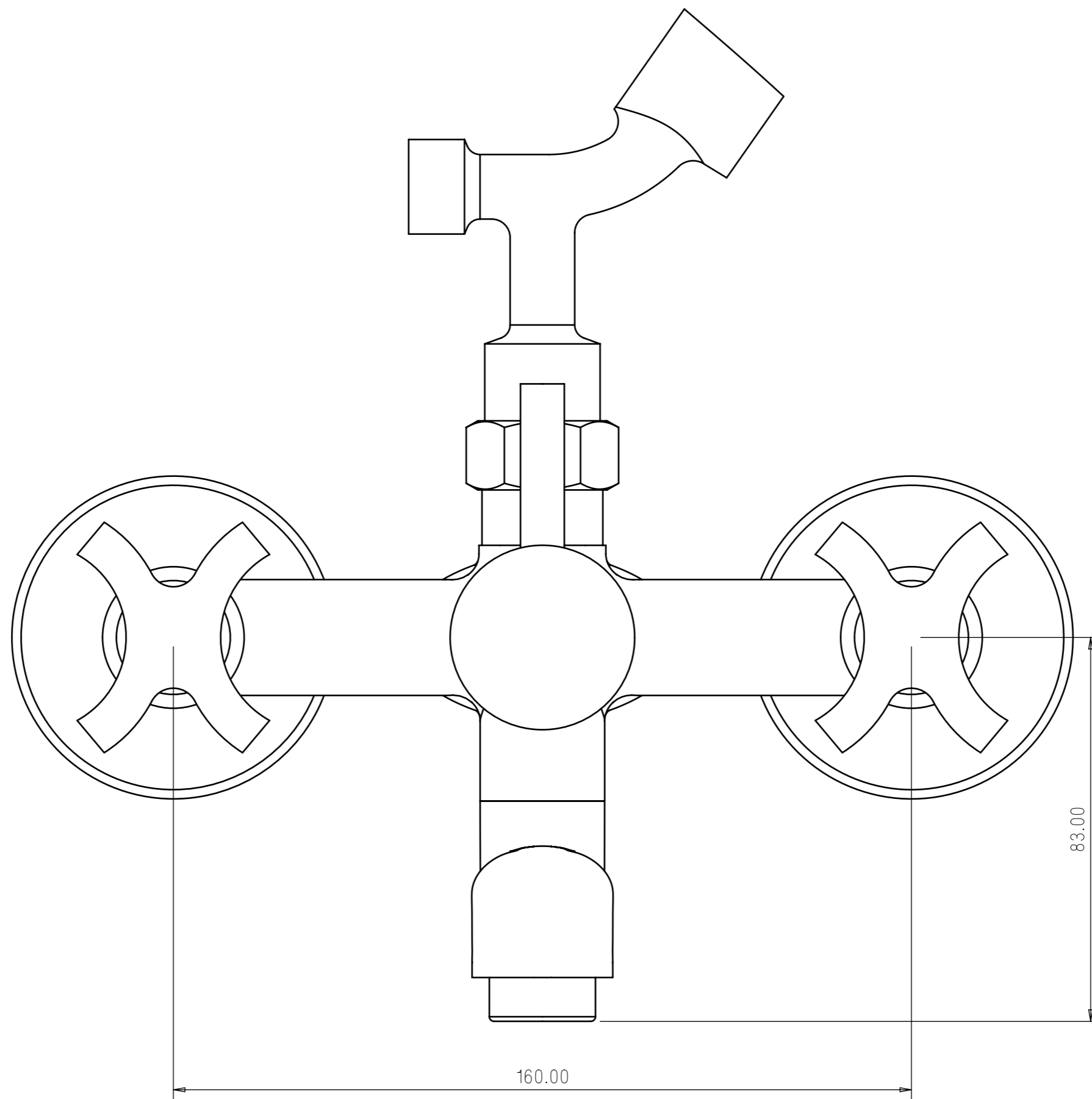

Flow Rate in LPM at			
0.5 BAR	1.0 BAR	2.0 BAR	3.0 BAR
6.00	9.50	14.00	16.50

SCALE -1:1

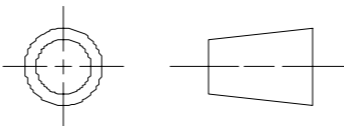

ALL DIMENSIONS IN MM

		PRAYAG POLYMERS (P) LTD.	
		A-1129, Phase-III, RIICO Indl.Area, Bhiwadi(Raj.)	
DRAWN BY		TITLE	
CHECKED BY		SIZE	DATE
TYPE		330.0 x 420.0	CAT NO 7470
		MATERIAL	WEIGHT

330.0 x 420.0

1

2

3

4

5

6

7

8

A

A

B

B

C

C

D

D

E

E

F

F